

Key



Mathematics 1201  
Common Mathematics Assessment

June 12, 2013

Name: \_\_\_\_\_  
 Mathematics \_\_\_\_\_  
 Teacher: \_\_\_\_\_

28 Selected Response  
13 Constructed Response

28 marks  
42 marks

**FINAL**

70 Marks

**FORMULAE**

**Surface Area**

<b>Cylinder</b> $2\pi r^2 + 2\pi rh$	<b>Cone</b> $\pi r^2 + \pi rs$	<b>Sphere</b> $4\pi r^2$
---	-----------------------------------	-----------------------------

**Volume**

<b>Pyramid</b> $\frac{1}{3}Ah$	<b>Cone</b> $\frac{1}{3}\pi r^2 h$	<b>Sphere</b> $\frac{4}{3}\pi r^3$
-----------------------------------	---------------------------------------	---------------------------------------

**Conversions**

1 foot = 12 inches	1 yard = 3 feet	1 mile = 1760 yards
1 inch = 2.54 centimetres $\approx$ 2.5 centimetres		1 mile $\approx$ 1.6 kilometres

**Selected Response:**

Circle the appropriate response on the answer sheet or SCANTRON.

1. Which is the best referent for one centimetre?

- (A) distance from the floor to a door knob
- (B) length of a five-dollar bill
- (C) thickness of a dime
- (D) width of a paper clip

2. What is the slant height of a cone with diameter 12 mm and height 17 mm?

- (A) 16 mm
- (B) 17 mm
- (C) 18 mm
- (D) 21 mm

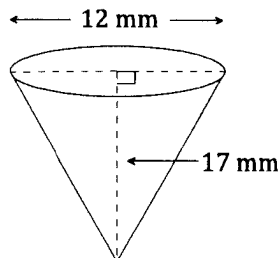

$$6^2 + 17^2 = h^2$$

$$325 = h^2$$

$$18.0 = h$$

3. What is 19.75 yards in yards, feet, and inches?

- (A) 19 yards, 2 feet, 3 inches
- (B) 19 yards, 2 feet, 6 inches
- (C) 19 yards, 2 feet
- (D) 19 yards, 9 inches

$$0.75 \times 3 = 2.25$$

$$0.25 \times 12 = 3$$

4. What is the adjacent side to  $\angle DAC$ ?

- (A) AD
- (B) BA
- (C) CA
- (D) DC

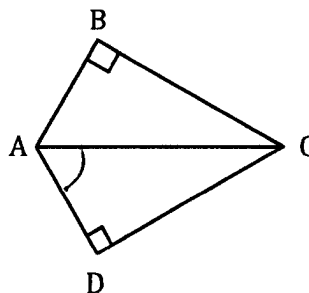

5. What is the measure of  $\angle A$ , to the nearest degree, if  $\tan A = 0.8725$ ?

- (A)  $34^\circ$
- (B)  $41^\circ$
- (C)  $49^\circ$
- (D)  $61^\circ$

6. Which ratio represents  $\sin B$ ?

- (A)  $\frac{5}{13}$
- (B)  $\frac{12}{13}$
- (C)  $\frac{13}{12}$
- (D)  $\frac{13}{5}$

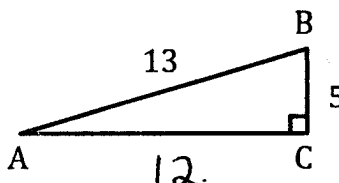

7. What is the length of side MA to the nearest tenth?

- (A) 2.0  
(B) 2.2  
(C) 3.9  
(D) 4.9

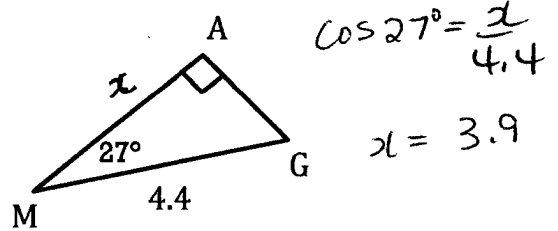

8. Simplify:  $\sqrt[3]{108}$

- (A)  $3\sqrt[3]{4}$   
(B)  $27\sqrt[3]{4}$   
(C)  $6\sqrt[3]{3}$   
(D)  $36\sqrt[3]{3}$

$$\sqrt[3]{27 \cdot 4} = 3\sqrt[3]{4}$$

9. Which statement is true about 3600?

- (A) It is a perfect cube.  
(B) Its only factors are 360 and 10.  
(C) Its square root is an irrational number.  
(D) Its prime factorization is  $2^4 \cdot 3^2 \cdot 5^2$ .

10. What is  $\sqrt[3]{5^2}$  expressed as a power?

- (A)  $5^{\frac{3}{2}}$   
(B)  $5^{\frac{2}{3}}$   
(C)  $5^{\frac{2}{3}}$   
(D)  $5^{\frac{3}{2}}$

$$5^{\frac{2}{3}}$$

11. A student did not receive full marks for her solution to the question below. In which step did she make the **first** error?

Simplify:  $\frac{(a^{-2}b^7)^{-5}}{(a^2b^{-3})^3}$

Solution:

Step 1:

$$\frac{a^{-7}b^2}{a^5b^0}$$

Step 2:

$$a^{-7-5}b^{2-0}$$

Step 3:

$$a^{-12}b^2$$

Step 4:

$$\frac{b^2}{-a^{12}}$$

- (A) 1  
(B) 2  
(C) 3  
(D) 4

12. Which binomial product is modelled?

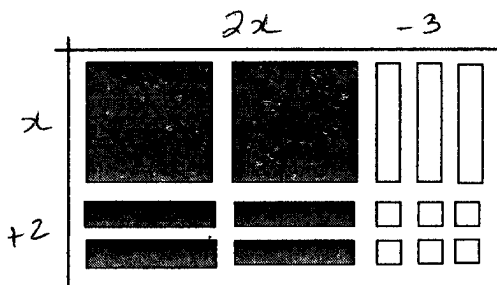

Note:  = negative  = positive

- (A)  $(-2x + 3)(-x + 2)$
- (B)  $(-2x + 3)(x + 2)$
- (C)  $(2x - 3)(x + 2)$**
- (D)  $(2x - 3)(x - 2)$

13. Expand and simplify:  $(a - 3b)(2a - b)$

- (A)  $2a^2 + 3b^2$
- (B)  $3a - 4b$
- (C)  $2a^2 - 7ab + 3b^2$**
- (D)  $3a^2 - 6ab - 4b^2$

$$2a^2 - ab - 6ab + 3b^2$$

$$2a^2 - 7ab + 3b^2$$

14. What is the greatest common factor of  $16x^2y^3$ ,  $8x^3y^2$ , and  $-24x^3y^3$ ?

- (A)  $4x^2y^2$
- (B)  $4x^3y^3$
- (C)  $8x^2y^2$**
- (D)  $8x^3y^3$

$$8x^2y^2$$

15. Factor completely:  $x^2 - 6x + 5$

- (A)  $(x - 1)(x - 5)$**
- (B)  $(x - 2)(x - 3)$
- (C)  $(x - 1)(x + 5)$
- (D)  $(x + 6)(x - 1)$

16. Factor completely:  $4x^2 - 36$

- (A)  $2(2x^2 - 18)$
- (B)  $4(x^2 - 9)$
- (C)  $(2x - 6)(2x + 6)$
- (D)  $4(x - 3)(x + 3)$**

$$4(x^2 - 9)$$

$$4(x + 3)(x - 3)$$

17. What is the missing value if the given polynomial is a perfect square trinomial?

$$25x^2 + [?] + 16$$

- (A)  $9x$
- (B)  $18x$
- (C)  $20x$
- (D)  $40x$**

$$\begin{array}{c} 20x \\ \sqrt{\phantom{20x}} \\ (5x + 4)(5x + 4) \\ \hline 20x \end{array}$$

18. If the amount of gas remaining in your gas tank is affected by the distance travelled, what is the dependent variable?

- (A) the amount of gas in your tank
- (B) the amount of time
- (C) the cost of gas
- (D) the distance travelled

19. Which set of ordered pairs represents a function?

- (A)  $\{(-3, -8), (-1, -7), (-2, -6), (-1, -5)\}$
- (B)  $\{(-8, 0), (-6, 5), (4, -1), (7, 0)\}$
- (C)  $\{(4, 1), (4, 2), (3, 4), (4, 4)\}$
- (D)  $\{(2, 5), (3, 8), (4, 11), (2, 1)\}$

20. The graph describes Mackenzie's activity during a bike ride. What does segment EF represent?

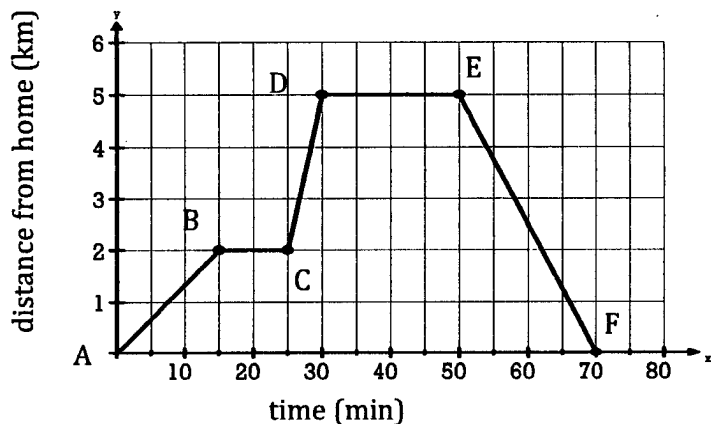

- (A) Mackenzie stops at a friend's house.
- (B) Mackenzie rides downhill.
- (C) Mackenzie leaves home.
- (D) Mackenzie returns home.

21. What is the domain of the function shown?

- (A)  $\{x \mid -3 < x \leq 3, x \in \mathbb{R}\}$
- (B)  $\{x \mid -3 \leq x \leq 3, x \in \mathbb{R}\}$
- (C)  $\{y \mid 0 \leq y \leq 3, y \in \mathbb{R}\}$
- (D)  $\{y \mid -3 < y \leq 0, y \in \mathbb{R}\}$

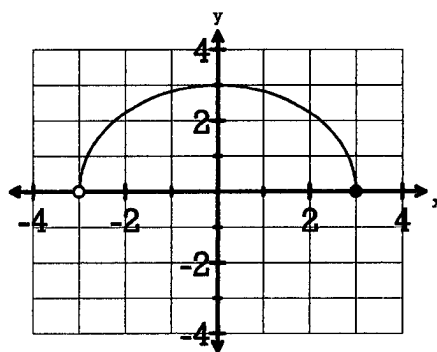

22. What is the rate of change in the given table?

- (A)  $\frac{1}{5}$
- (B)  $\frac{1}{2}$
- (C) 2
- (D) 5

d	C(d)
0	75
10	77
20	79
30	81
40	83

$10 <$   $> +2$   
 $\frac{2}{10} = \frac{1}{5}$

23. What is the equation of the line graphed?

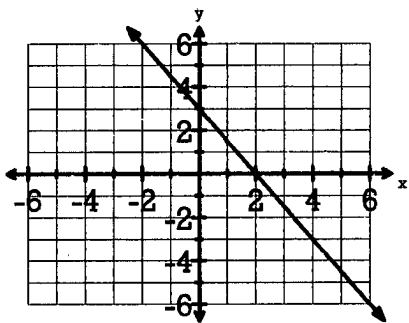

(A)  $y = -\frac{3}{2}x + 2$

(B)  $y = -\frac{3}{2}x + 3$

(C)  $y = -\frac{2}{3}x + 2$

(D)  $y = -\frac{2}{3}x + 3$

24. What is the slope of a line **perpendicular** to  $y = -\frac{1}{7}x + 5$ ?

(A)  $-7$

(B)  $-\frac{1}{7}$

(C)  $\frac{1}{7}$

(D)  $7$

$\frac{1}{7}$

25. What is the equation of the line, in slope-point form, that has slope  $\frac{4}{5}$ , and passes through the point  $(9, -1)$ ?

(A)  $y - 1 = \frac{4}{5}(x + 9)$

(B)  $y - 1 = \frac{5}{4}(x + 9)$

(C)  $y + 1 = \frac{4}{5}(x - 9)$

(D)  $y + 1 = \frac{5}{4}(x - 9)$

26. What is the expression for the slope between points  $(a, b)$  and  $(c, d)$ ?

(A)  $\frac{a - b}{c - d}$

(B)  $\frac{a - c}{b - d}$

(C)  $\frac{c - d}{a - b}$

(D)  $\frac{d - b}{c - a}$

$\frac{d - b}{c - a}$

27. Which system models the given situation?

A collection of nickels ( $n$ ) and dimes ( $d$ ) contains four times as many dimes as nickels. The total value of the collection is \$20.25.

(A)  $\begin{cases} d = 4n \\ 0.05d + 0.10n = 20.25 \end{cases}$

(B)  $\begin{cases} d = 4n \\ 0.10d + 0.05n = 20.25 \end{cases}$

(C)  $\begin{cases} n = 4d \\ 0.05n + 0.10d = 20.25 \end{cases}$

(D)  $\begin{cases} n = 4d \\ 0.10n + 0.05d = 20.25 \end{cases}$

28. How many solutions does the given system have?

$$y = \frac{4}{6}x + 8$$

$$y = \frac{2}{3}x - 4$$

$\swarrow$   $y = \frac{2}{3}x + 8$   
parallel

- (A) none  
(B) one  
(C) two  
(D) infinite

**Constructed Response:**

Answers to be written on this paper in the space provided. Show all workings.

29. A shed is constructed by using a rectangular prism for the walls with a triangular prism for the roof. Determine the surface area of the shed to the nearest square foot. (Do not include the shed floor.)

[4 points]

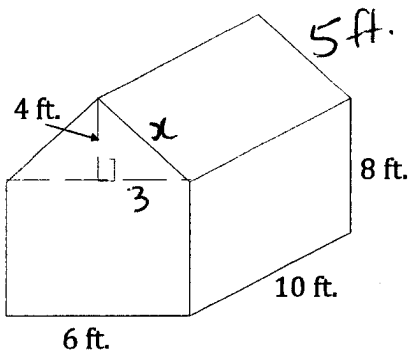

$$3^2 + 4^2 = x^2$$

$$25 = x^2 \quad \textcircled{1}$$

$$5 = x$$

Rectangular:

Front =  $6 \times 8 = 48$

Back = 48

① Right =  $10 \times 8 = 80$

Left = 80

Triangular

Front =  $\frac{b \times h}{2} = \frac{6 \times 4}{2} = 12$

① Back = 12

Right =  $10 \times 5 = 50$

Left = 50

① SA =  $2(48) + 2(80) + 2(12) + 2(50) = 380 \text{ ft}^2$

30. A right square pyramid has a volume of  $182.4 \text{ cm}^3$ . Determine the side length of its base to the nearest cm. [2 points]

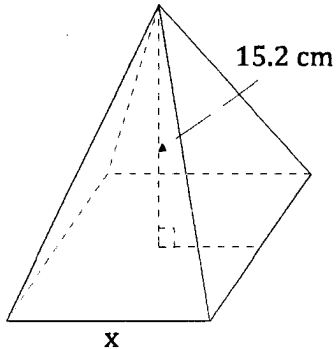

$$V = \frac{lw h}{3}$$

$$182.4 = \frac{x \cdot x \cdot 15.2}{3} \quad \textcircled{1}$$

$$3 \cdot \frac{182.4}{15.2} = x^2 \quad \textcircled{2}$$

$$36 = x^2 \quad \textcircled{3}$$

$$\sqrt{36} = x$$

$$6 = x \quad \textcircled{4}$$

31. From the top of a 50 m building, an observer spots two joggers. The first jogger is at an angle of depression of  $45^\circ$  and the second is at an angle of depression of  $30^\circ$ . How far apart (to the nearest tenth of a metre) are the two joggers? [4 points]

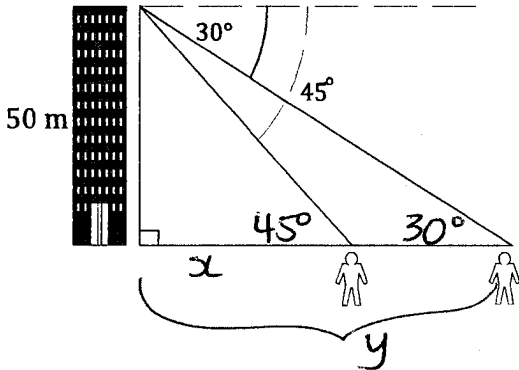

Distance between joggers is

$$86.6 - 50 \quad \textcircled{1}$$

$$= \boxed{36.6 \text{ m}}$$

$$\tan 45^\circ = \frac{50}{x} \quad \textcircled{1}$$

$$\tan 30^\circ = \frac{50}{y} \quad \textcircled{1}$$

$$x = \frac{50}{\tan 45^\circ} = 50 \quad \textcircled{2}$$

$$y = \frac{50}{\tan 30^\circ} = 86.6 \quad \textcircled{2}$$

32. A polling organization uses the telephone book to randomly select people for a survey. They choose every 20<sup>th</sup> person to ask question #1, every 28<sup>th</sup> person to ask question #2, and every 30<sup>th</sup> person to ask question #3. In which position in the phone book is the first person to be asked all three questions? [3 points]

LCM:

20	28	30	}
^	^	^	
4.5	4.7	6.5	
^ 1	^ 1	^ 1	
2.2.5	2.2.7	2.3.5	
<u>2<sup>2</sup>.5</u>	<u>2<sup>2</sup>.7</u>	<u>2.3.5</u>	②

$$\text{LCM} = 2^2 \cdot 5 \cdot 7 \cdot 3 = 420 \quad \textcircled{1}$$

The 420<sup>th</sup> person is the first one to be asked all 3 questions.



33. The area of a square is  $121x^4y^2$ . What is the expression for the perimeter of the square? [2 points]

$$\text{side} = \sqrt{121x^4y^2} = 11x^2y \quad \textcircled{1}$$

$$\text{Perimeter} = 4(11x^2y) = \boxed{44x^2y} \quad \textcircled{1}$$

34. Simplify:  $\left(\frac{-54x^6y}{2x^{-3}y^4}\right)^{\frac{4}{3}}$  [4 points]

$$\textcircled{1} \begin{cases} = (-27x^{6-(-3)}y^{1-4})^{\frac{4}{3}} \\ = (-27x^9y^{-3})^{\frac{4}{3}} \end{cases}$$

$$\textcircled{1} = (-27)^{\frac{4}{3}} (x^9)^{\frac{4}{3}} (y^{-3})^{\frac{4}{3}}$$

$$\textcircled{1} = (\sqrt[3]{-27})^4 (x^{12}) (y^{-4})$$

$$\textcircled{\frac{1}{2}} = (-3)^4 x^{12} y^{-4} = \boxed{\frac{81x^{12}}{y^4}} \quad \textcircled{\frac{1}{2}}$$

35. Expand and simplify:  $(2x-5)(x+7)^2$  [3 points]

$$\textcircled{\frac{1}{2}} = (2x-5)(x+7)(x+7)$$

$$\textcircled{\frac{1}{2}} \begin{cases} = (2x-5)(x^2+7x+7x+49) \\ = (2x-5)(x^2+14x+49) \end{cases}$$

$$\textcircled{\frac{1}{2}} = 2x^3 + 28x^2 + 98x - 5x^2 - 70x - 245$$

$$\textcircled{\frac{1}{2}} = \boxed{2x^3 + 23x^2 + 28x - 245}$$

36. Determine the expression, in simplest form, for the area of the shaded region: [3 points]

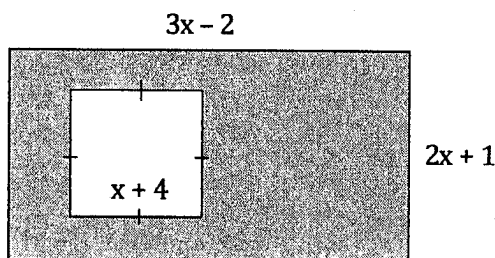

$$\text{Rect. Area} = (3x-2)(2x+1) \stackrel{\textcircled{\frac{1}{2}}}{=} 6x^2 + 3x - 4x - 2 \quad \textcircled{+}$$

$$\stackrel{\textcircled{\frac{1}{2}}}{=} 6x^2 - x - 2$$

$$\text{Square Area} = (x+4)(x+4) \stackrel{\textcircled{\frac{1}{2}}}{=} x^2 + 4x + 4x + 16 \quad \textcircled{+}$$

$$\stackrel{\textcircled{\frac{1}{2}}}{=} x^2 + 8x + 16 \quad \textcircled{+}$$

$$\text{Shaded Area} = (6x^2 - x - 2) - (x^2 + 8x + 16) = \boxed{5x^2 - 9x - 18}$$

37. Factor completely:  $5x^2 - 9x - 18$  [3 points]

$$\begin{array}{l}
 (5x^2 - 15x) + (6x - 18) \\
 5x(x-3) + 6(x-3) \\
 \boxed{(x-3)(5x+6)} \text{ (2) ?}
 \end{array}$$

$\begin{array}{cc} \oplus & \otimes \\ -9 & -90 \\ \hline & -15, 6 \end{array} \text{ (1) ?}$

38. The cost of printing advertising flyers for a school play is represented by the function  $C(f) = 0.80f + 10.00$ , where  $C$  is total cost in dollars and  $f$  is the number of flyers. [4 points]

a) If  $C(f) = 86.00$ , determine the value of  $f$ . Explain what this situation means.

$$\begin{array}{l}
 \text{(1/2)} \quad 86.00 = 0.80f + 10.00 \\
 86.00 - 10.00 = 0.80f \\
 \frac{76.00}{0.80} = \frac{0.80f}{0.80} \\
 \text{(1/2)} \quad 95 = f
 \end{array}$$

This means that 95 flyers could be printed for 86.00. (1)

b) Does this function represent discrete or continuous data? Explain.

(1) This is discrete data because you cannot print "half" of a flyer (or "part" of a flyer.) (1)

39. Write the equation, in the form  $Ax + By + C = 0$ , of the line that passes through the points  $(4, 5)$  and  $(-6, 10)$ . [3 points]

$$\begin{array}{l}
 \text{slope} = \frac{10 - 5}{-6 - 4} = \frac{5}{-10} = -\frac{1}{2} \text{ (1/2)} \\
 y = -\frac{1}{2}x + b \\
 5 = -\frac{1}{2}(4) + b \text{ (1/2)} \\
 5 = -2 + b \\
 5 + 2 = b \\
 7 = b \text{ (1/2)} \\
 y = -\frac{1}{2}x + 7 \text{ (1/2)} \\
 \frac{1}{2}x + y - 7 = 0 \text{ (1/2)} \\
 2(\frac{1}{2}x + y - 7) = 0 \\
 \boxed{x + 2y - 14 = 0} \text{ (1/2)}
 \end{array}$$

40. A trapezoid is defined as a quadrilateral with exactly one pair of parallel sides. Show that the points  $A(-3, -1)$ ,  $B(-2, 6)$ ,  $C(2, 8)$ , and  $D(7, 4)$  can be joined to form a trapezoid. [3 points]

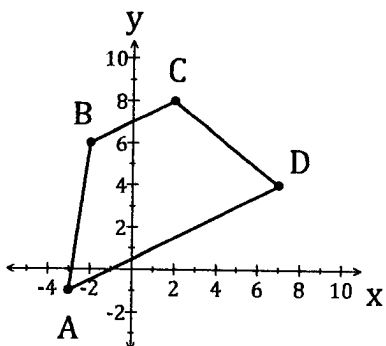

$$\left(\frac{1}{2}\right) m_{AB} = \frac{6 - (-1)}{-2 - (-3)} = \frac{7}{1} = 7$$

$$\left(\frac{1}{2}\right) m_{BC} = \frac{8 - 6}{2 - (-2)} = \frac{2}{4} = \frac{1}{2}$$

$$\left(\frac{1}{2}\right) m_{CD} = \frac{4 - 8}{7 - 2} = -\frac{4}{5}$$

$$\left(\frac{1}{2}\right) m_{AD} = \frac{4 - (-1)}{7 - (-3)} = \frac{5}{10} = \frac{1}{2}$$

$BC \parallel AD$  since slopes are the same.

$\left(\frac{1}{2}\right) AB \nparallel CD$  ... different slopes.

$\left(\frac{1}{2}\right) ABCD$  is a trapezoid because it has exactly one pair of parallel sides.

41. Solve:  $\begin{cases} \frac{3}{2}x - 2y = -8 \\ 4x + 3y = -13 \end{cases} \rightarrow 2\left(\frac{3}{2}x\right) - 2(2y) = 2(-8)$  [4 points]

$$3x - 4y = -16$$

$$3x - 4y = -16 \xrightarrow{\times 3} 9x - 12y = -48$$

$$4x + 3y = -13 \xrightarrow{\times 4} 16x + 12y = -52$$

$$\frac{25x}{25} = \frac{-100}{25}$$

$$x = -4$$

$$4(-4) + 3y = -13$$

$$-16 + 3y = -13$$

$$3y = -13 + 16$$

$$\frac{3y}{3} = \frac{3}{3}$$

$$y = 1$$

$$(-4, 1)$$

1201 Common Mathematics Assessment - June 2013  
Answer Sheet

Name \_\_\_\_\_

Mathematics Teacher: \_\_\_\_\_

- 1. A B C  D
- 2. A B  C D
- 3.  A B C D
- 4.  A B C D
- 5. A  B C D
- 6. A  B C D
- 7. A B  C D
- 8.  A B C D
- 9. A B C  D
- 10. A B  C D
- 11.  A B C D
- 12. A B  C D
- 13. A B  C D
- 14. A B  C D
- 15.  A B C D
- 16. A B C  D
- 17. A B C  D
- 18.  A B C D
- 19. A  B C D
- 20. A B C  D
- 21.  A B C D
- 22.  A B C D
- 23. A  B C D
- 24. A B C  D
- 25. A B  C D
- 26. A B C  D
- 27. A  B C D
- 28.  A B C D